

SOLAR COLLECTORS

The GOBI line of solar flat-plate collectors is one of the industry's highest-rated. Over 30 years of design and engineering refinement have gone into making it a world-class performer for heat output, efficiency, and durability. The collector is available in three sizes, with two surface types to choose from (blue sputtered and black paint), making it suitable for all types of solar heating applications.

Features

- Low-profile tapered design for a subtle rooftop presence
- Optimal heat absorption and overall efficiency
- Certified to withstand 50 lbs. per square foot
- Anodized aluminum frame improves durability & rigidity
- No-solder connections with factory installed DYN-O-SEAL unions
- Rated by SRCC and IAPMO as one of the industry's best-performing collectors



DOS unions are included to connect collectors

ABSORBER SURFACES

Blue sputtered coating (Variant 001)

- Optimal heat absorption with minimal emission
- Suitable for all installations & regions
- Recommended for cool climates

Black paint coating (Variant 002)

- An economical choice
- Adequate heat absorption in ideal climate regions
- Best for warm climates with ample solar radiation

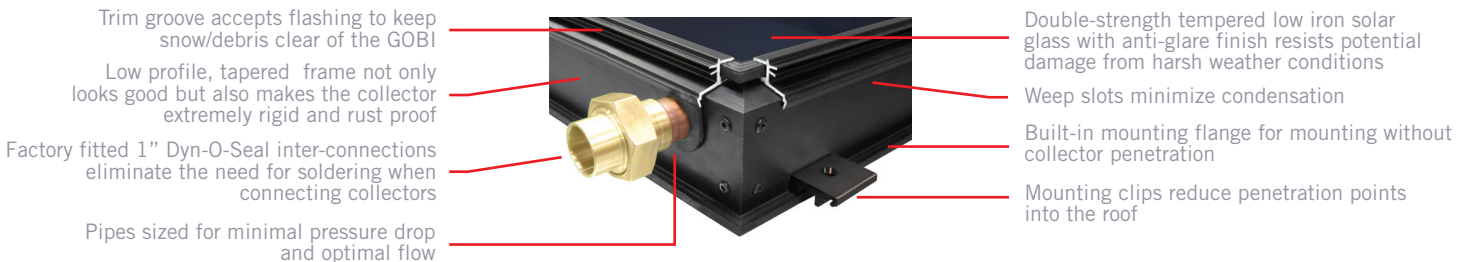

TECHNICAL SPECIFICATIONS

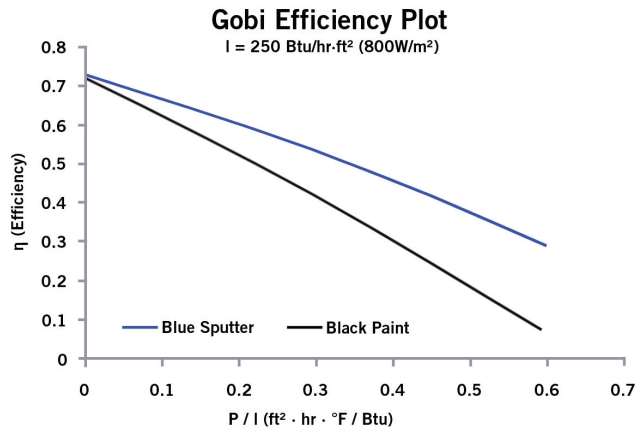
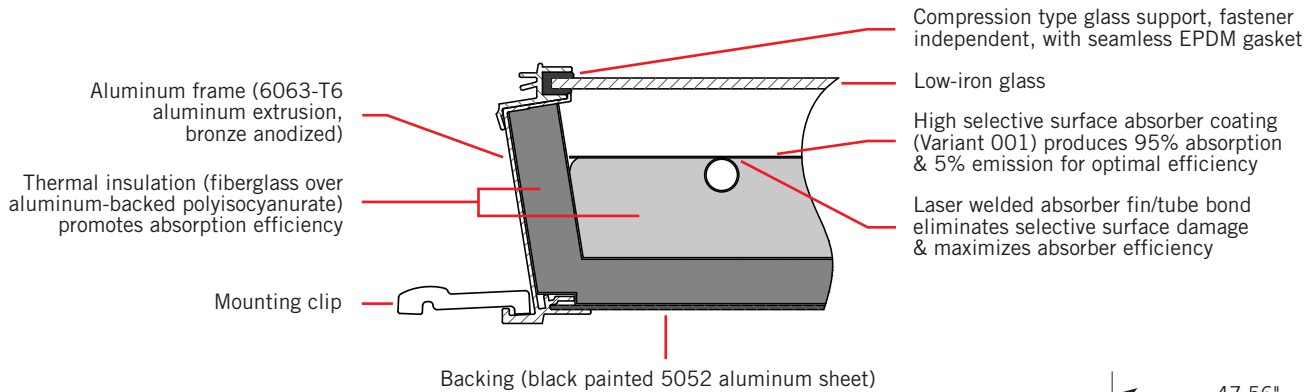

Gross Area Efficiency Curve

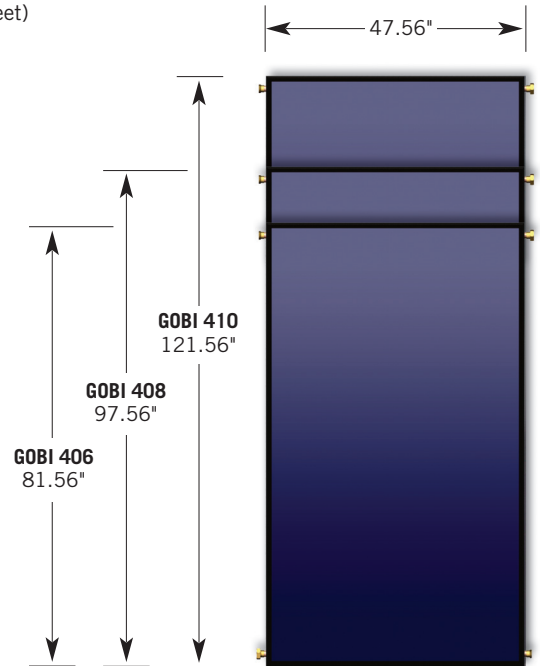

Note: GOBIs all have a depth of 3.9"

REFERENCE AREA	BLACK PAINT GROSS	BLACK PAINT NET	BLUE SPUTTER GROSS	BLUE SPUTTER NET
$C_0 (-)$	0.7190	0.7783	0.7300	0.7902
$C_1 \text{ (BTU / HR FT}^2 \text{ °F)}$	0.9358	1.0130	0.6006	0.6501
$C_2 \text{ (BTU / HR FT}^2 \text{ °F)}$	0.0010	0.0011	0.0010	0.0011

PRODUCT CODE

GOBI 406

GOBI 408

GOBI 410

Dimensions, Weights, Capacities

Gross Area	26.94 ft ²	32.22 ft ²	40.15 ft ²
Net Area	24.90	29.93	37.47
Dry Weight	102 lbs	126 lbs	153 lbs
Fluid Capacity	1 gal	1.14 gal	1.34 gal

Ratings & Certifications

Maximum Operating Pressure	150 psi (10.34 Bar)	150 psi (10.34 Bar)	150 psi (10.34 Bar)
Wind Load Certification	50 psf (2.39 kPa)	50 psf (2.39 kPa)	50 psf (2.39 kPa)

PTLS 000 006 042308

Heliodyne, Inc. • 4910 Seaport Avenue • Richmond, CA 94804
 T: 510.237.9614 • F: 510.237.7018 • www.heliodyne.com
 Information & Support: info@heliodyne.com

heliodyne[™]
 SOLAR HOT WATER